

Pneumatic Automatic Bollard



Series No.DBO-168/220/275P4

Series No.DBO-168/220/275P0

TECHNICAL MANUAL

Verb 1.0

Contents

1. SAFETY INSTRUCTIONS 3

2. DESCRIPTION 4

 2.1. Description of the series and definitions 4

 2.2. Location of the components 5

3. INSTALLATION 7

 3.1. Cylinder installation 7

 3.2. Cabinet installation 9

4. Adjustment and use 12

 4.1. Cabinet adjustment 12

 4.2. Bollard working speed adjustment 13

5. Control Panel 14

6. Heating system (optional) 16

 6.1. Components 16

 6.2. Installation 17

 Progress of how to connect the heating cable to power line 17

 6.3. Working principle and use 20

1. SAFETY INSTRUCTIONS

ATTENTION! To ensure the safety of people, it is important that you read all the following instructions. Incorrect installation or incorrect use of the product could cause serious harm to people.

1. Carefully read the instructions before beginning to install the product.
2. Do not leave the packing materials (plastic, polystyrene, etc.) within reach of children as such materials are potential sources of danger.
3. Store this user guide for future reference.
4. This product was designed and built strictly for the use indicated in this documentation. Any other use, not expressly indicated here, could compromise the good condition/operation of the product and/or be a source of danger.
5. DELOS declines all liability caused by improper use or use other than that for which the automated system was intended.
6. Do not install the equipment in an explosive atmosphere: the presence of inflammable gas or fumes is a serious danger to safety.
7. For non-EU countries, to obtain an adequate level of safety, the Standards mentioned above must be observed, in addition to national legal regulations.
8. DELOS is not responsible for failure to observe Good Technique in the installation of the DELOS products and relating accessories or for any deformation that may occur during use.
9. Installation must be preformed in compliance with the currently Ruling Standards.
10. Before attempting any job on the system, cut out electrical power.
11. Make sure that the earthing system is perfectly constructed, and connect metal parts to it.
12. The safety devices (EN 12978 standard) protect any danger areas against **mechanical movement risks**.
13. Do not in any modify the components of the DELOS automated system.
14. The installer shall supply technical support, including manual operation of the bollard in case of an emergency, and shall hand over to the user the warnings handbook supplied with the product.
15. Do not allow children or adults to stay near the bollard while it is operating.
16. The user must not attempt any kind of repair or direct action whatever and contact qualified personnel only.
17. **Anything not expressly specification in these instructions is not permitted.**

2. DESCRIPTION

2.1. Description of the series and definitions

The pneumatic bollard has been designed to control access to a site with a high level of security, guaranteeing pedestrian access but blocking the area to road traffic. The pneumatic bollard include bollard and the control cabinet:

Case One



Bollard

Case Two



Control Cabinet

2.2. Location of the components

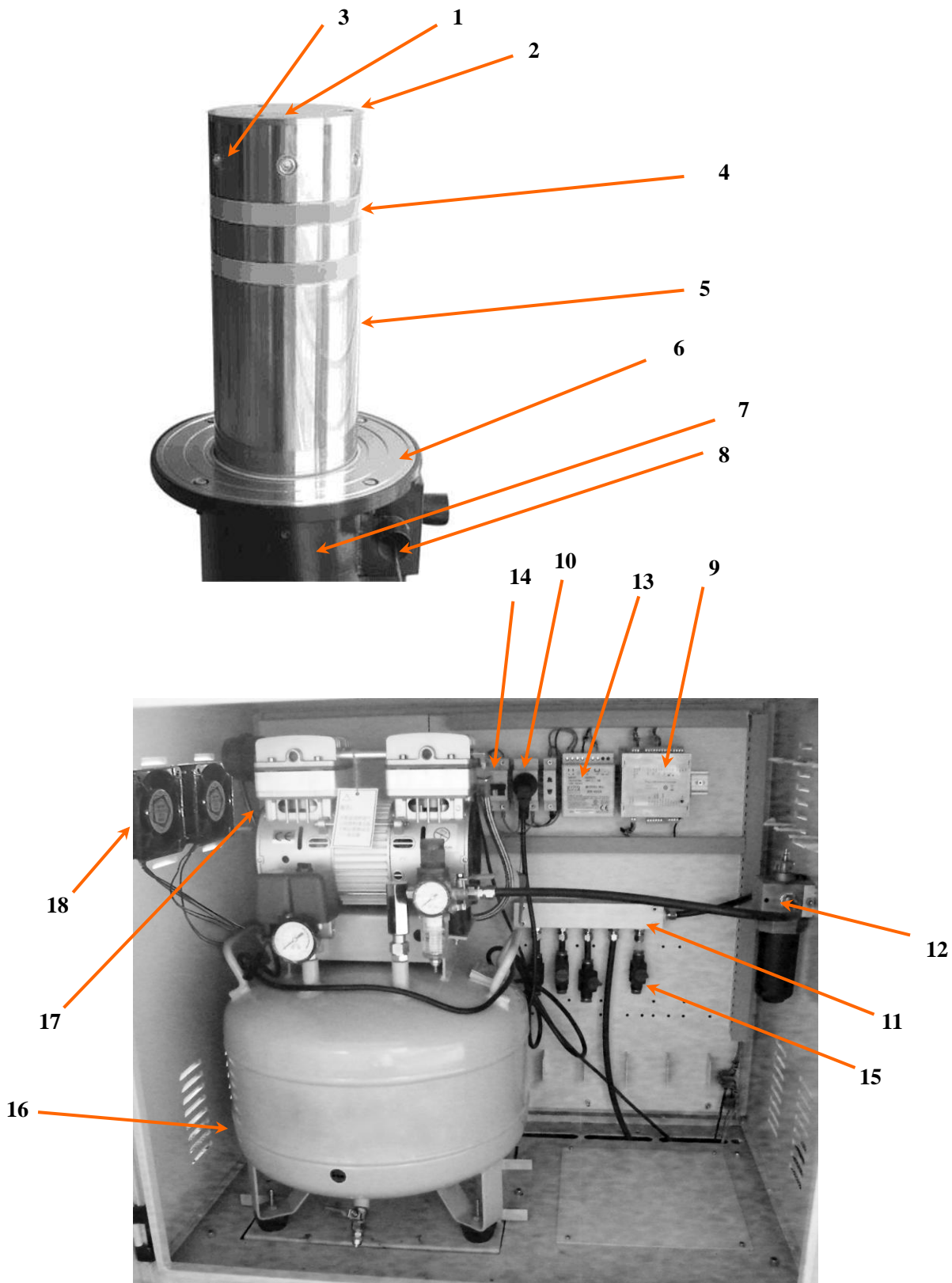

1. Top cover
2. Anti-theft screw
3. LED
4. Reflector tape
5. Cylinder
6. Flange
7. Underground parts
8. Receptacle outlet
9. Control panel
10. Power socket
11. Valve
12. Air cleaner
13. DC 24V power supplier
14. Switch
15. Air tap and joint
16. Air container
17. Air pump
18. Fans

3. INSTALLATION

3.1. Cylinder installation

1. Make sure that the place where the DELOS bollard is to be installed is not a low-lying; or it need install drainage channel equipped with covering grid to protect the DELOS bollard with.
2. Dig up to a hole about 0.8m² and as following depth according your length of bollard. (As our experience, we dig a long deep channel if there is a lot of bollard in one line.)

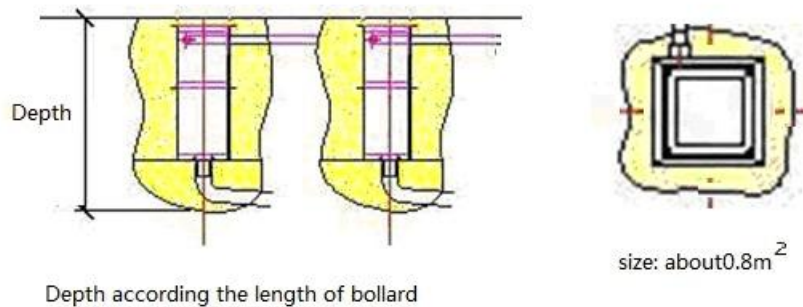

The depth of hole	The length of raising bollard
1200mm	600mm
1350mm	750mm
1500mm	900mm



3. Make sure that the ground is able to absorb water: pour about 40L water in the dig and check if draining takes place within 30 minutes. If this is not the case, discharge rainwater by means of a pipeline with a diameter of 100mm connected to the drainage system or, as an alternative, connected to a pit equipped with a drainage system (i.e. motor pump) for the collection and drainage of rainwater.
4. Put gravel (Diameter of approx. 8-20mm) on the bottom to obtain a thickness of about 30cm, taking care to compact it well to avoid future settlements.

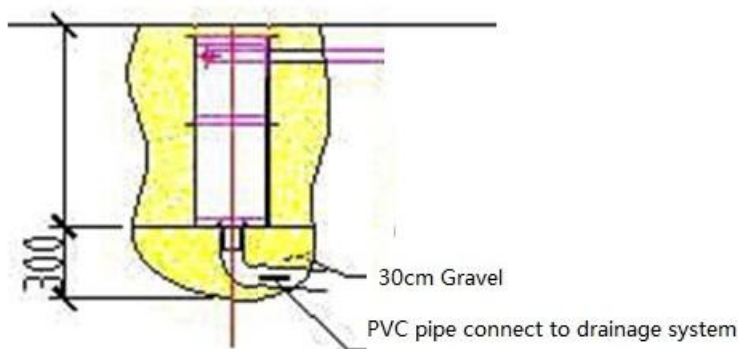

5. Install the bollard underground parts inside of the hole, taking care to position it vertical. Raise the cylinder to the highest position and make sure all the bollards are on the same line and level.



6. In the condition of good drainage system, fill the hole with concrete or Ram down with soil to approx. 30-50cm from the floor surface.

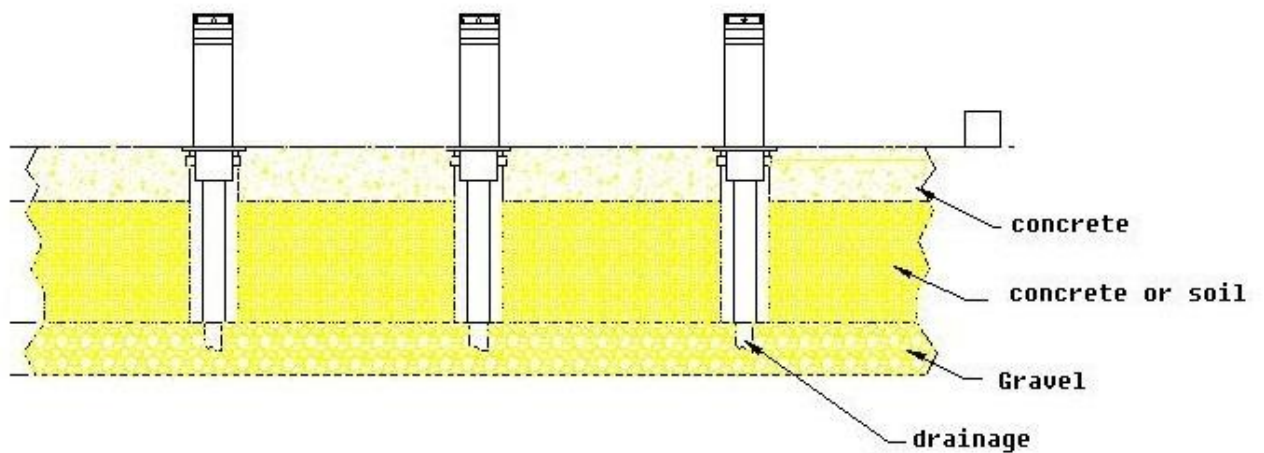

7. Lay the necessary pipes for the connection between the control cabinet and bollard. Use PVC pipe or soft wired hose (a diameter of approx. 32mm) within:
 - a) 1 air pipes (a diameter of 10mm, different colours to tell out/in)
 - b) 1.5 mm² two core power lines in for Control valve
 - c) 1.5 mm² two core power lines in for LED.
 - d) 1 cm² three core shielded power cord for heating system (optional)
 - e) It is suggested that one pipe for one bollard for the convenience of future maintenance.

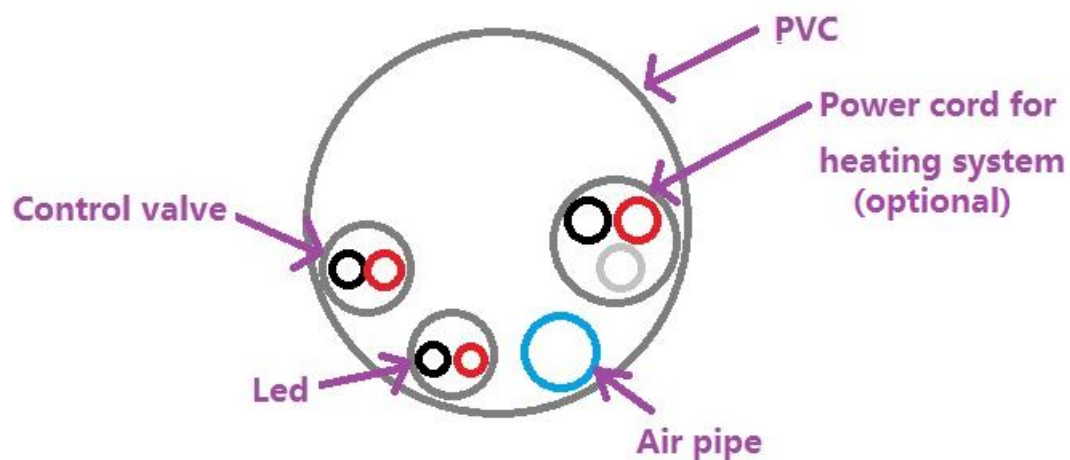

8. Connect air pipe joint, LED lines, control valve lines and heating system power cord lines. Check the air tightness and whether the light is normal. (Detail see P10)
9. If every component has tested normally, use proof fabric to airproof the receptacle outlet.
10. Continue to cast concrete up to the level of floor in the condition of promising the tightness between PVC pipe and external vat joint.
11. The top level of the flange must be approx. 10mm higher than the floor surface to limit the inlet of rainwater in the pit.



3.2. Cabinet installation

1. Choose suitable place (i.e. guard house nearby, place suitable for surrounding). Place it within 30m from bollard, or it will influence the bollard sensitivity.
2. If the distance between bollard and the cabinet is $>100\text{m}$, gas holder must be embedded in the middle.
3. A fundamental platform should be made, it is about $1\text{m} * 0.7\text{m}$. In it, pipe connect to cabinet and power 220V/110V inlet line pipe are embedded. Cabinet is placed on the fundamental platform, fixed by four M12 mental expansion bolts.

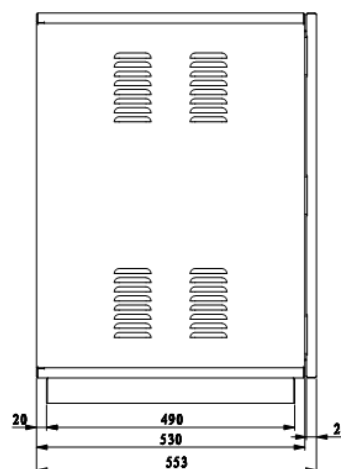
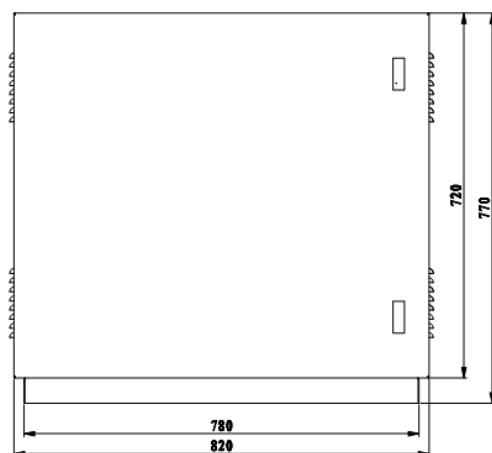

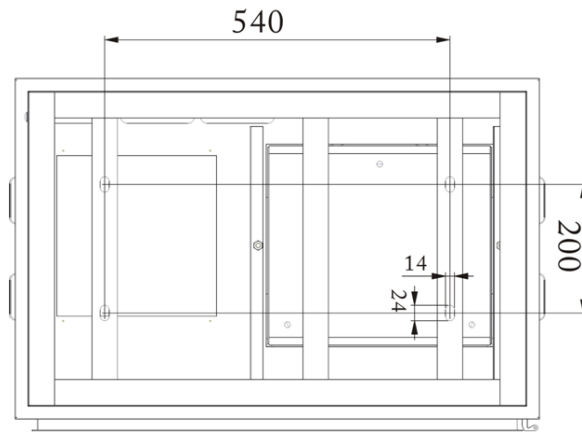

4. Connect the embedded air pipe to the joint in the cabinet, close other air taps.

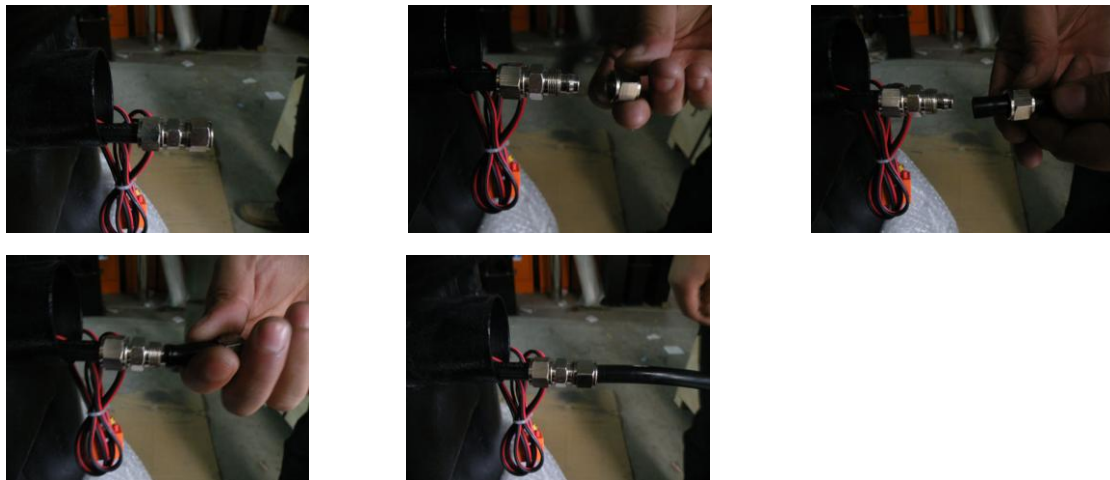

5. Parallel connect LED line and control valve line of all bollards then and then connect them to the reserved line in the cabinet according connector label. (See following pictures)

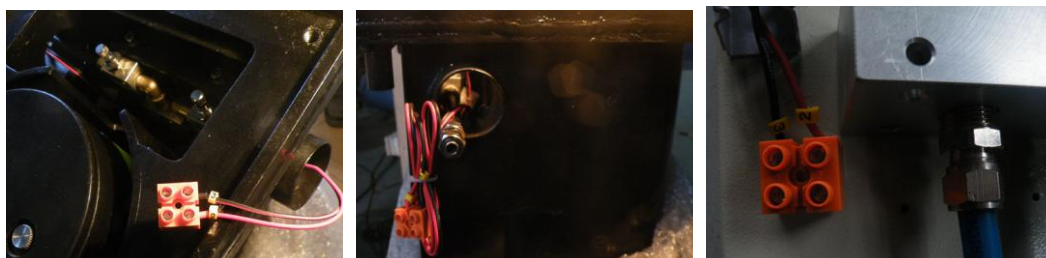

6. Connect the power cords of heating system to the reserved socket. (Optional)
7. Socket in the air pump, turn on air switch, the circuit panel indicate light will on, air pump begins to work.

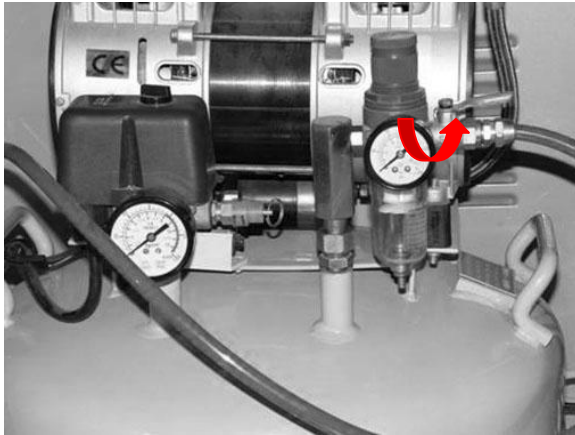

4. Adjustment and use

4.1. Cabinet adjustment

1. Socket in the air pump, turn on air switch, the circuit panel indicate light will on, air pump begins to work. It will stop until the pressure of the air holder comes to 8 kg. Turn on the red valve (horizontal with the air pipe).



2. There are two gauges on the air pump, on the left is air holder pressure gauge (this one indicates the pressure in the air holder), the one near to the air out valve is working pressure gauge, Adjust the working pressure gauge to make the needle to the position of 4KG (it is always adjusted in the factory).
 - a) Adjust method: Pull up the knob near to working pressure gauge, turn right to increase working pressure, turn left to decrease working pressure.
 - b) Run the bollard after the adjustment until the working pressure is stable, and then press the knob.

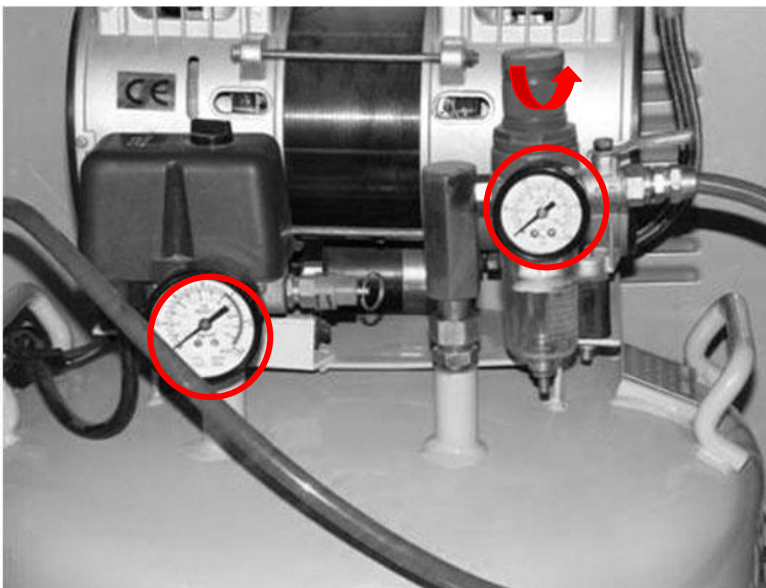

4.2. Bollard working speed adjustment

All bollards have been adjusted speed in factory. If you need adjust their speed, please

- 1) Open the flange
- 2) Turn on the left knob of governor valve to adjust rise speed.
- 3) Turn on the right knob of governor valve to adjust down speed.

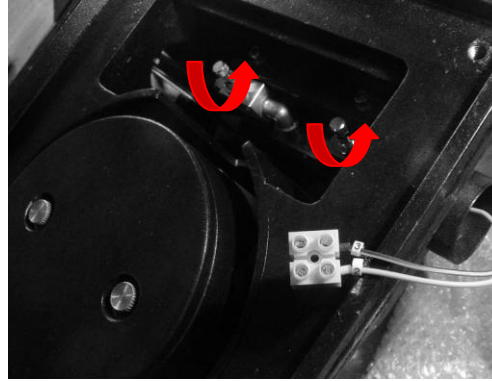
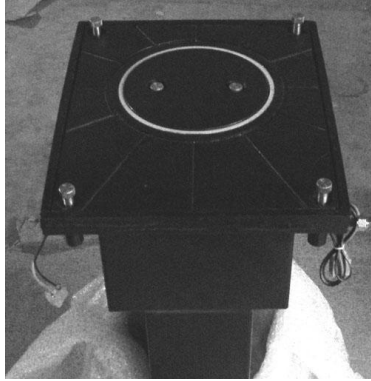

5. Control Panel

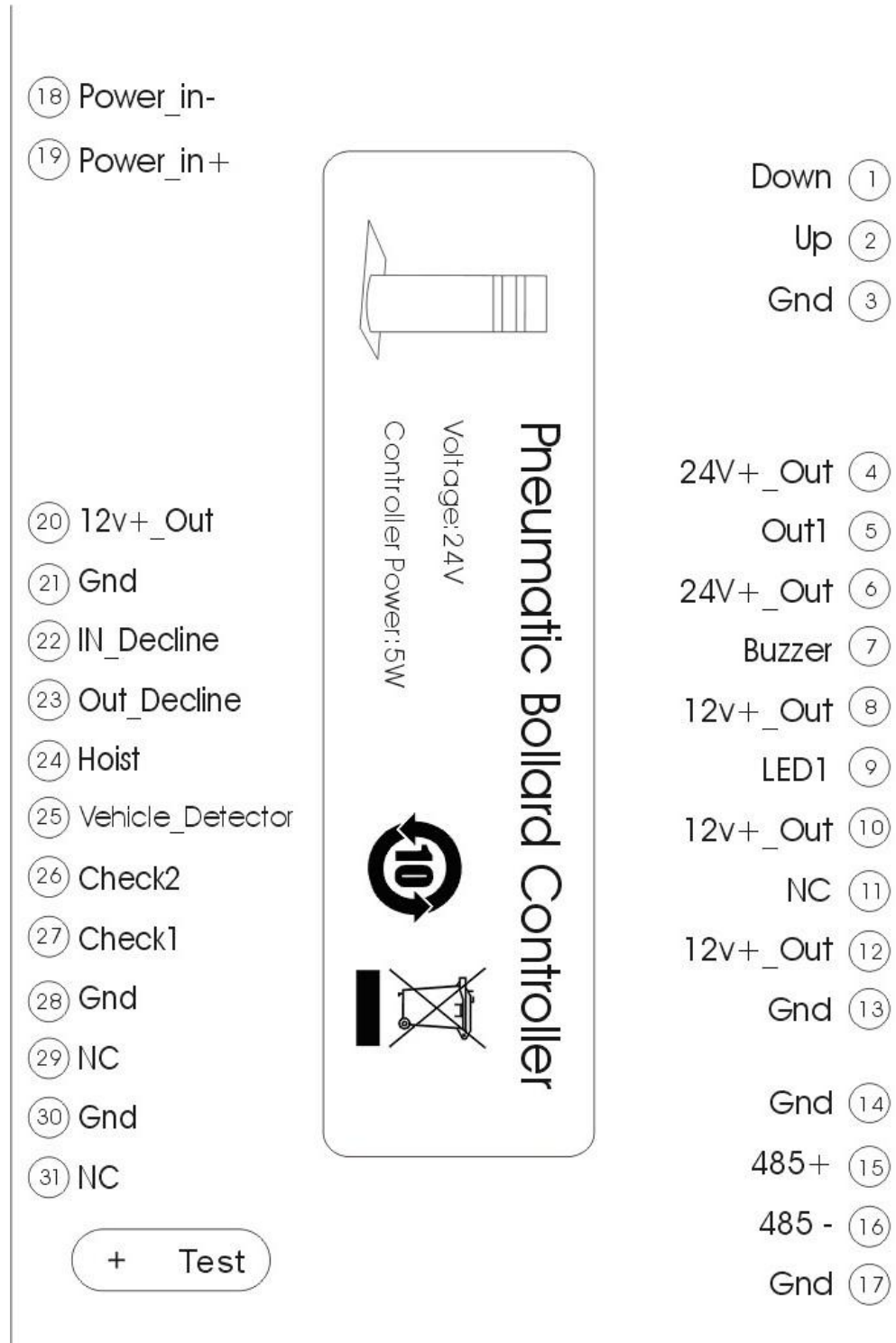

NO.	Terminal	Use	No.	Terminal	Use
1	Down	Lower Signal Output (connect to valve)	17	Gnd	Gnd
2	Up	Rising Signal Output (connect to valve)	18	Power in-	Gnd (Power in)
3	Gnd	Common Port Output (connect to valve)	19	Power in+	24V+ Input (Power in)
4	24V+Out	24V+ Output (reserved)	20	12V+ Out	12V+ Output (reserved)
5	Out	NC (reserved)	21	Gnd	Gnd
6	24V+Out	Alarm 24V+ Output (reserved)	22	Down_dirction1	Lower Signal Input 1 (connect to lower signal form direction 1)
7	Buzzer	Alarm OC Output (reserved)	23	Down_dirction2	Lower Signal Input 2 (connect to lower signal form direction 2)
8	12V+Out	LED 12V+ Output (connect to LED +)	24	Hoist	Rising Signal Input (connect to rising signal)
9	LED1	LED OC Output (connect to LED -)	25	Vehicle Detector	Safety Loop input
10	12V+Out	12V+ Output (reserved)	26	Check 2	Direction Loop 2
11	NC	NC (reserved)	27	Check 1	Direction Loop 1
12	12V+Out	12V+Output (reserved)	28	Gnd	Gnd
13	Gnd	Gnd	29	NC	NC (reserved)
14	Gnd	Gnd	30	Gnd	Gnd (reserved)
15	485+	485+ (connect to master 485+)	31	NC	NC
16	485-	485- (connect to master 485-)			

Notice: Please use a switch, TTL or a low level pulse (>100ms) to be the input signal.

+ Test

There is a black button for debugging, press for rise and lower.

In factory the manufacturer have connected all the cables for default standard function, the other disconnect ports are reserved for advance function.

6. Heating system (optional)

The heating system is design for cold enticement, it's a safety product and also very easy installation and using. It's Waterproof, use special material of sleeve for long time thermal stability.

6.1. Components

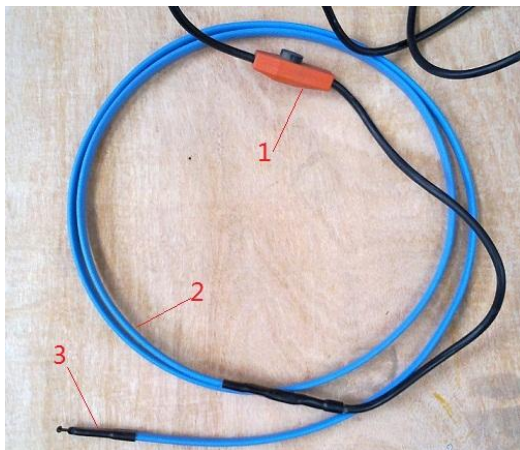

1. Temperature Detector 2. Heating Material 3. End Coupler

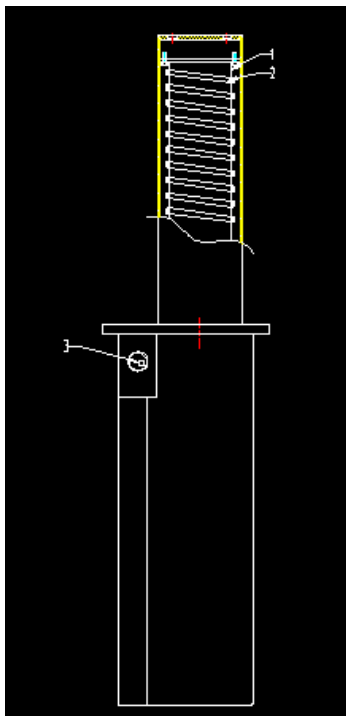

1. Heating fixed barrel 2. Heating material 3. Outside hole of heating cable

6.2. Installation

The installation of heating system is quite easy, for the bollard just needs connect the power cords with 220V/110V power directly, for the heating system in cabinet, just push in power socket in cabinet directly to get power.

Attention:

1. Because the power is 220V/110V, please confirm the waterproof ability of connector underground in PVC.
2. Every heating system in bollard should has independent power line, and inside in a protection PVC which motioned in chapter 3.7.

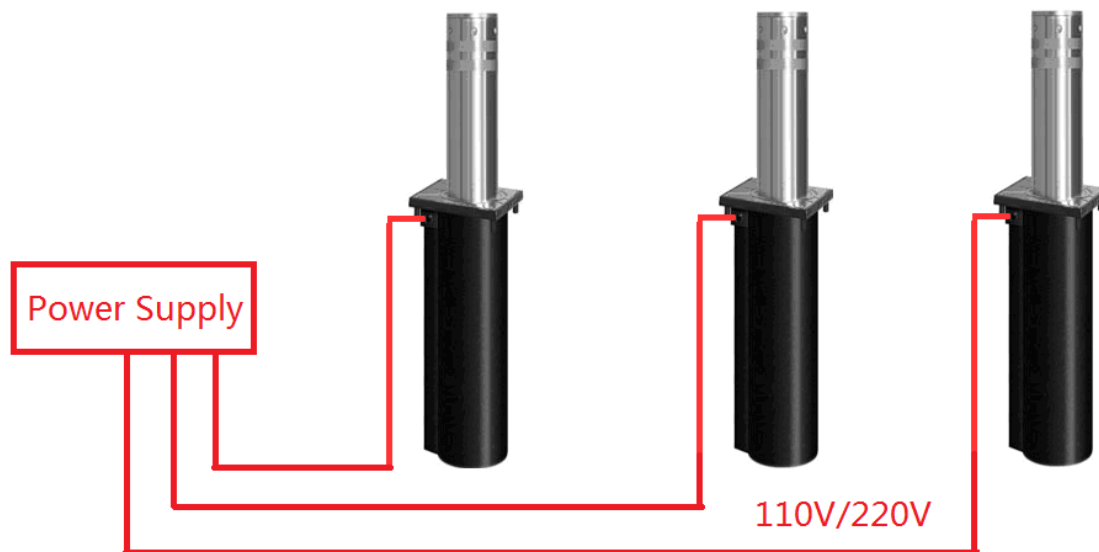

Progress of how to connect the heating cable to power line

1. Remove the shield of power line, emerge the inside core.

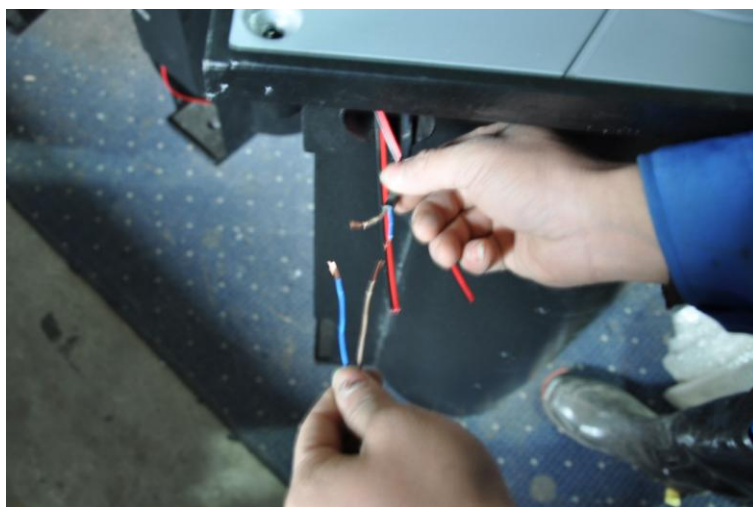

2. Cover heat-shrinkable tubes. (Attention: must cover every cable and the outside shield, total 3.)



3. Welding the power line to heating cable.

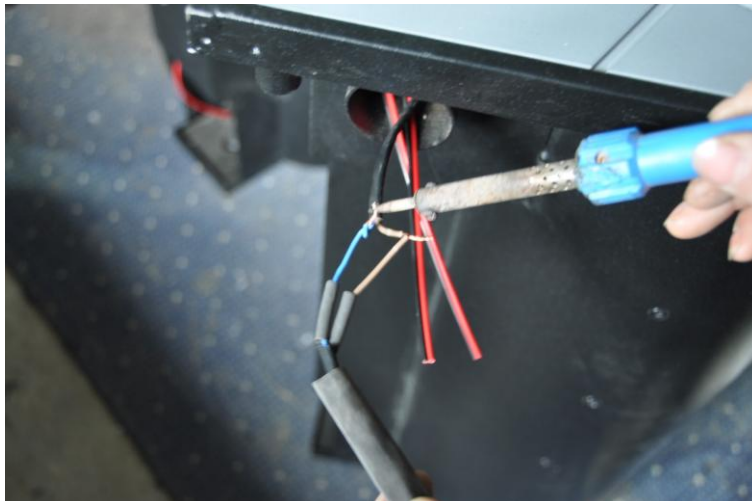

4. Heat the heat-shrinkable tubes in every cable, let them shrink.



5. Bind cable with waterproof rubberized fabric, must be very tight.



6. Heat the outside heat-shrinkable tubes, confirm its tight



8. Insert all inside of the cable hole, then connect power to test heating system working.

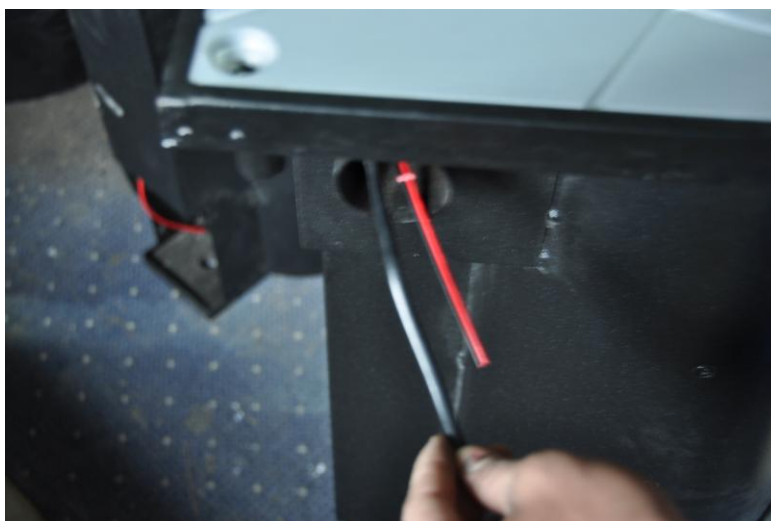

6.3. Working principle and use

The heating system includes heating material and temperature detector. It will heat bollard automatically if detect temperature is below 4C and stop 40C (inside temperature, not cylinder surface.)

If you don't need use heating system any more, just pull out its plug.