

Swing Barrier

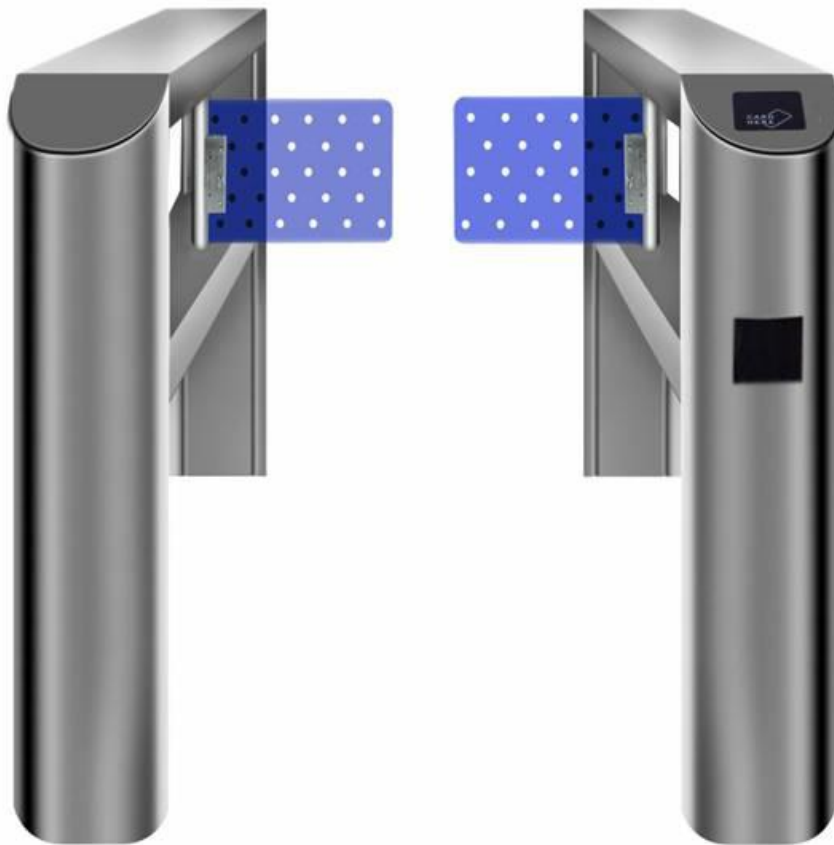

Series No.DSB-400

TECHNICAL MANUAL

Verb 1.0

Contents

1. SAFETY INSTRUCTIONS	3
2. DESCRIPTION.....	4
2.1. Description of the series and definitions	4
2.2. Location of the components	5
2.3. Symbols.....	6
2.4. Detection cells.....	7
2.5. Mechanical group.....	8
2.6. Electrics connection draft.....	8
2.7. Principle of operation.....	9
2.8. Intrusions.....	10
2.8.1. “Standby” intrusion.....	10
2.8.2. “Following after authorized passage” intrusion	10
2.8.3. “Counter direction” intrusion	11
2.8.4. “Stay” intrusion.....	11
3. INSTALLATION	11
3.1. Preliminary work on site	11
3.2. Storage of the equipment before installation.....	11
3.3. Opening way for maintenance cover.....	12
3.4 Fixing of the pedestal	12
3.5. Electrical connections	13
3.6. Install reader.....	14
4.1. Adjust the limiter.....	15
4.2. Adjust the detection cell.....	15
4.3. Replacing the arms	16
4.4. Adjust the clutch.....	16
4.5. Detail of inside electronic connection	18
4.5.1 Main board	18
4.5.2 Slave board.....	19
4.6. Software adjust.....	22
4.7 Main board keypad operation.....	23
5. USE	26
5.1. Startup.....	26
5.2. Working mode.....	26
5.2.1 Normal close (default mode).....	26
5.2.2 Normal open.....	27
5.2.3 Emergency open mode	27
5.2.4 Emergency close mode	27
5.2.5 Degradation mode	27
5.3. Trouble shooting	28
5.4. Maintenance.....	28

1. SAFETY INSTRUCTIONS

The placement of an access control barrier imposes responsibilities on the user with respect to the safety of people:

For the users

- The barrier must be completely visible to the user as well as to any operator before being actuated.
- Safety detection cell for keep open position when people block it. (See 2. 3 Detection cells)
- Keep 10cm distance between every passenger in access.
- The barriers could thus be closed again on users/objects lower than this height without a cell detecting them.
- Please don't stay in access a long time.
- Please don't swing violently or sideways through in passing access.
- Consequently, it is strongly recommended to prohibit access in this case to pushchairs, unaccompanied children, animals on a lead, etc. The risk could however be limited by accompanying these users/objects with a larger user.

For the technical staff

- All operations on the equipment must be carried out by qualified personnel. Any unauthorized operation or carried out by a technician not qualified on this product voids the manufacturer's guarantee automatically.
- The access keys to the mechanism must be used by personnel who are aware of the electric risks and mechanics that it incurs in the event of negligent handling. These personnel must lock the access door to the mechanism after the operation.
- Any modify for electronic connection, please make sure cut off the supply.
- Any internal element likely to be put under voltage or moving must be handled with caution.
- The equipment is configured in a "normal close" mode default for its users. Any changes to the parameters must be carried out with full knowledge of the facts by qualified personnel and is not responsibility of Delos international group. (See 5.2.2 other working mode)

2. DESCRIPTION

2.1. Description of the series and definitions

The SWING BARRIER control the access of pedestrians with or without luggage, in bi-directions, guaranteeing high levels of security and safety.

The Swing barrier can be installed singly (Case One) or in a group (Case Two).

By definition:

DSB-400L: The left barrier, 1pcs main board (code 1) and 1pcs slave board (code 1-1) inside.

DSB-400R: The right barrier, 1pcs slave board (code N-2) inside.

DSB-400M: The intermediate barrier, 1pcs main board (code N) , 1pcs slave code (N-1)-2, and 1pcs slave board code N-2 inside.

Case One



DFB-400L

DFB-400R

Case Two



DFB-400L

DFB-400M

DFB-400R

Case Three

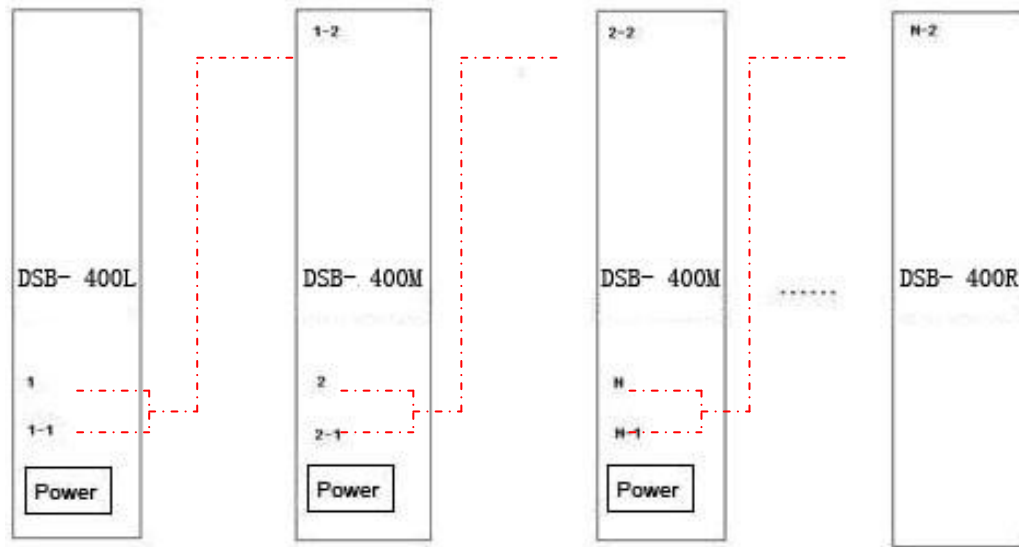

Refer to Case Three, the code in main board and slave is for connection convenience. Every access is controlled by according main board (N), slave board(N-1), slave board (N-2), the detail please see 3.5 Electrical connections.

2.2. Location of the components

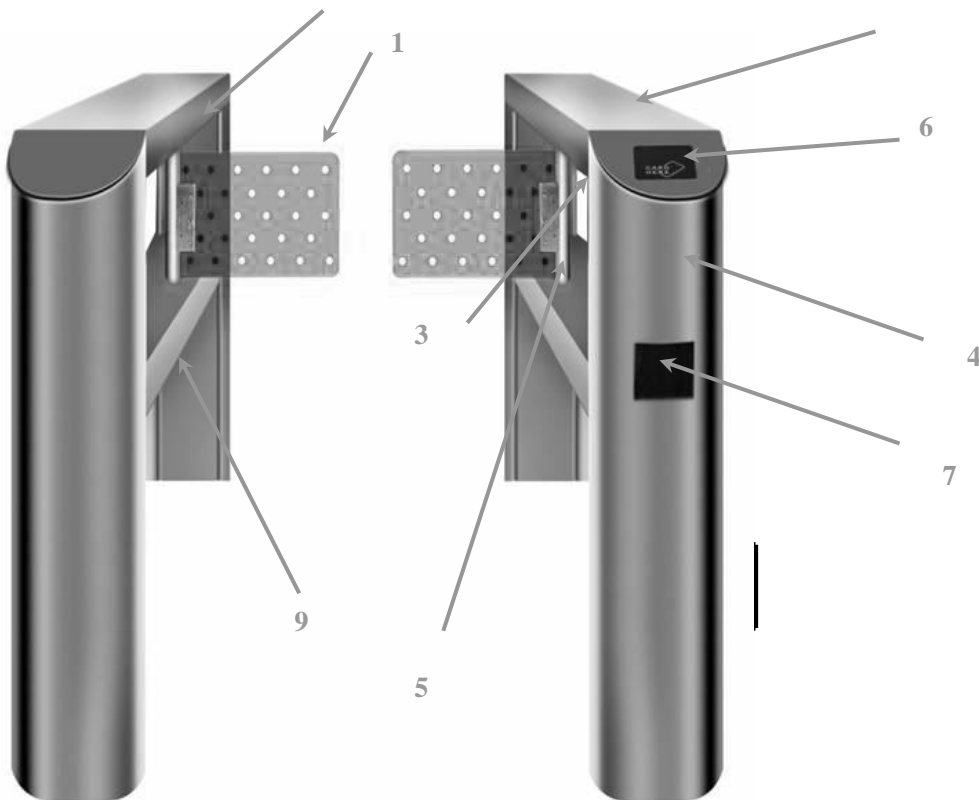

1. Swing arm
2. Top cover
3. Lock
4. Front cover
5. Axes of arm
6. Operate symbols (can install reader under it)
7. Orientation symbols
8. Intrusion logic detection cell
9. Safety detection cell

2.3. Symbols

This Swing barrier equipped with two types of pictograms:

Operate symbols (can install reader under it) indicating the state of the authorized feedback to the user. They are located on the top cover: green track (authorized successfully) or red crosses (waiting authorization).



Orientation symbols: Indicating the access situation to user. This is located on the front cover and consists of a symbol representing the illuminated in 3 different situation:

- Red crosses: Passage forbidden until authorization succeeds



- Green track: Authorization succeeds, waiting the valid passage.



- Red crosses flashing: Invalid passage or other alarming happen, clear barrier and shield authorization for 10s



2.4. Detection cells

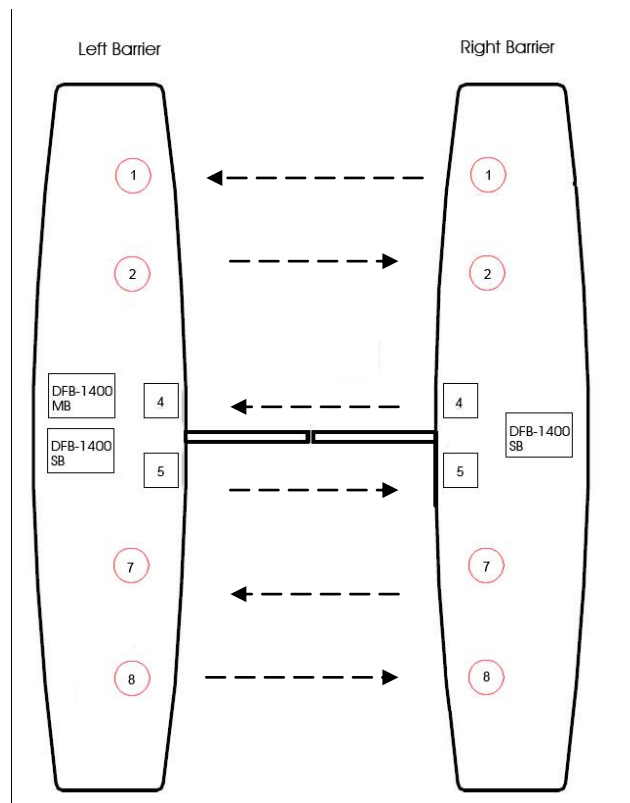
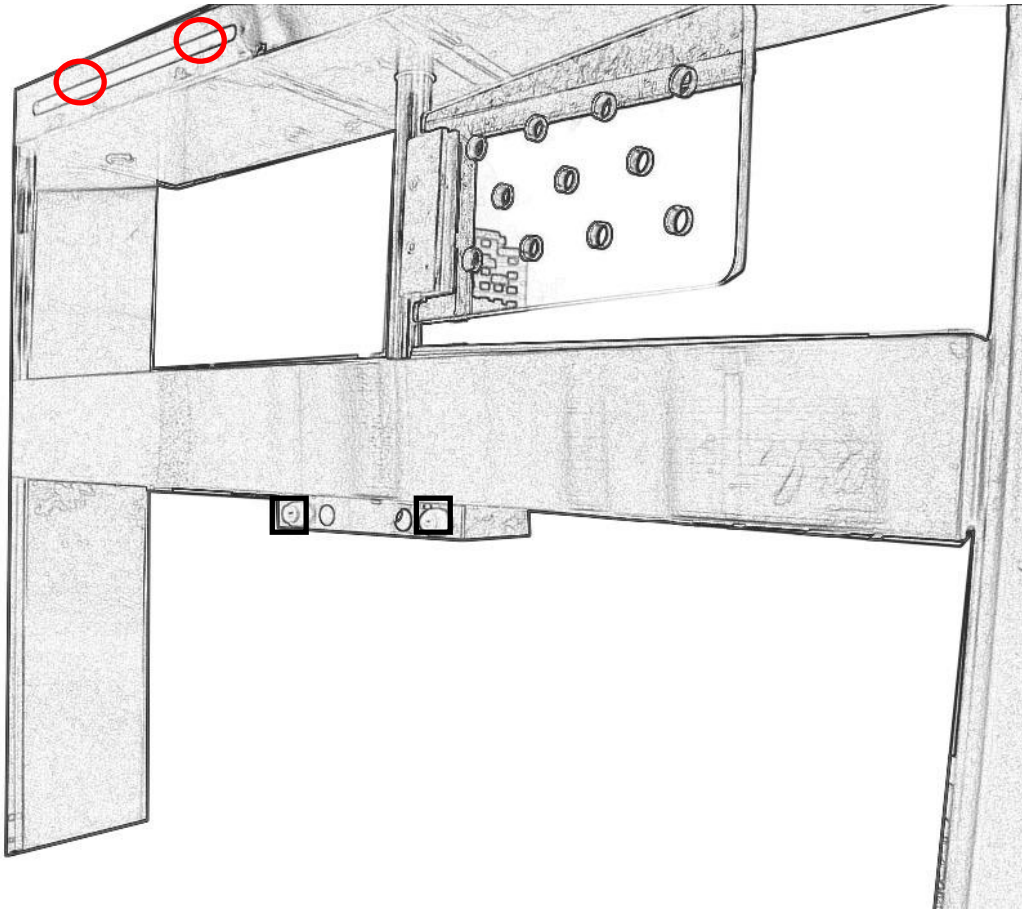



: Intrusion detection cell



: Safety detection cell



: Main board



: Slave board

All the cells are Transmitter/Receiver type: the signal emitted by the transmitter cell is received by the receiver cell on the other side. It's 6 couples of cell in this product, defined as 1,2,4,5,7,8

The transmitter and receiver are staggered, the transmitters 2, 5, 8 and receivers 1, 4, 7 are in left barrier, other are in right barrier.

The detection cells are laid in horizontal group and define 2 zones (intrusion detection cell and safety detection cell), the different zone is different functions.

Intrusion detection cell: ensures the management of passage; counts the number of passages in each direction; detect different type of intrusion.

Safety detection cell: guarantees the safety of the user by preventing the closing of the barriers when there is a presence in this zone (without distinguishing between authorized and unauthorized users). Enforce the safety of children by lowering the zone of detection

*More detail, please see 4.2 Adjust the detection cell.

2.5. Mechanical group

Please see 4. ADJUSTMENTS AND OPERATIONS.

2.6. Electrics connection draft

Left barrier

Right barrier

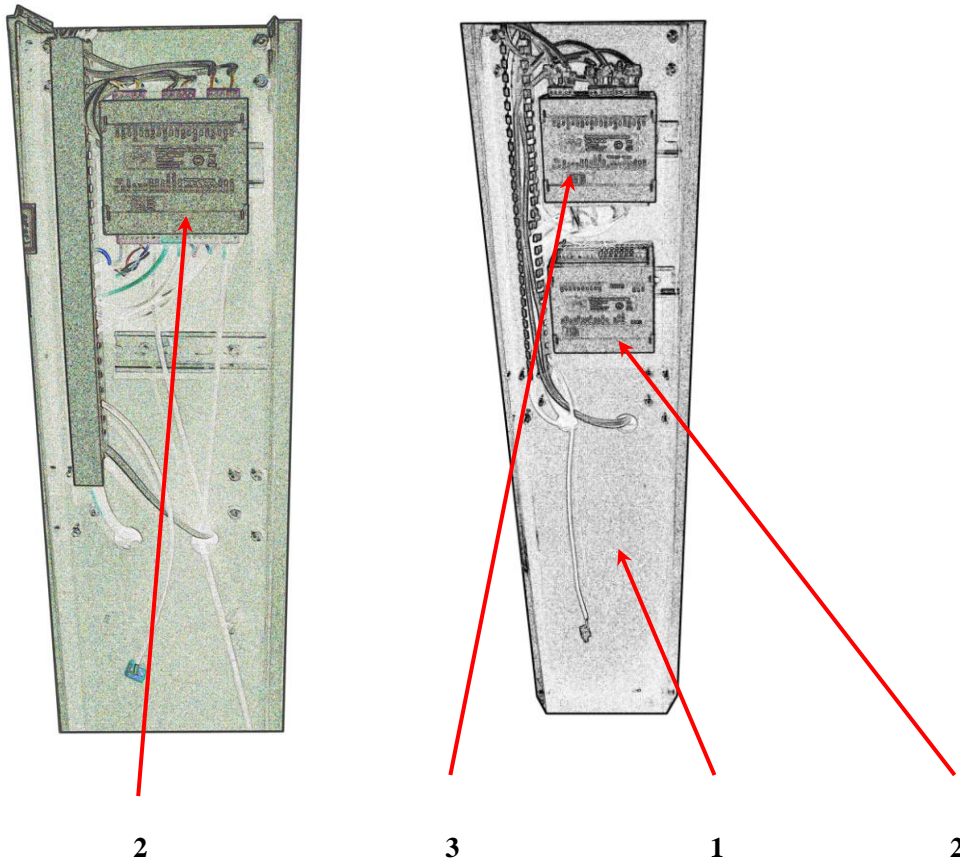

1. General power supply
2. Slave board
3. Main board

2.7. Principle of operation

The main board managing the barrier receives a request for passage (caused by masking the first cells, a pushbutton, a access controller, any input signal, etc) and releases the passage if the conditions are met .

By default, the authorizations of passage are stored in memory 10s per time: if several authorizations are granted, they will be added and will grant that many passages.

If authorized but not detect any passenger, the buzzer will sound and symbols will flash to prompt passenger.

Other details please see ‘5.2 Working Mode’.

2.8. Intrusions

Intrusions are abnormal (unauthorized) movements in access.

During the detection of an intrusion, whatever it is:

- The buzzer sounds
- The output reply in main board will output the according trigger signal
- The orientation symbols change to red and keeping flashing, shield all input open signal(detail see following item)
- After the cause of the intrusion has been removed, the barrier then returns to the state it was in before the intrusion.

Note: When detect this intrusion, the buzzer will sounds and output according signal. The “alarming” timer can be set by software.

2.8.1. “Standby” intrusion

When the barrier is on standby, an intrusion is detected as soon as there is an obstruction of cells 1.

Alarming time: 3s

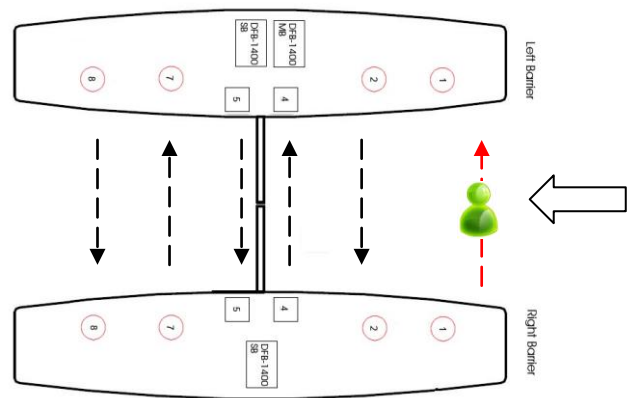

2.8.2. “Following after authorized passage” intrusion

After the passage of the barriers by an authorized person, another person following in the same direction and without authorization causes an intrusion.

Alarming time: 3s

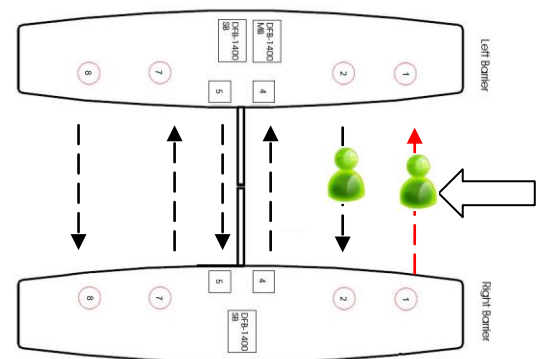

2.8.3. “Counter direction” intrusion

The intrusion is declared when a person is authorized in a direction while a passage in the other direction is in progress

Alarming time: 3s

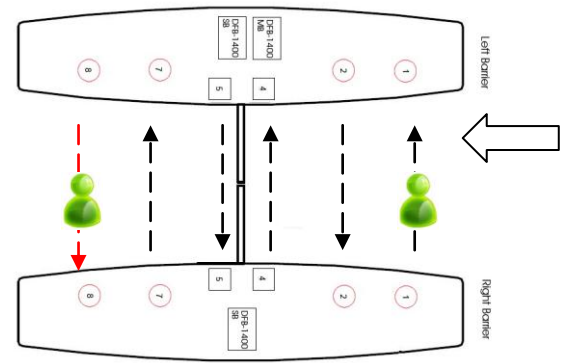

2.8.4. “Stay” intrusion

After the authorized and detected have gone into the access but don't detect finish the passage. The barrier will keep open and waiting 25s. Then barrier will output “stay” intrusion and close in 30s. Unless passenger block the safety detection cell, the arms will close when he leave the detection cell.

Alarming time: start at 25s after detect gone into the access.

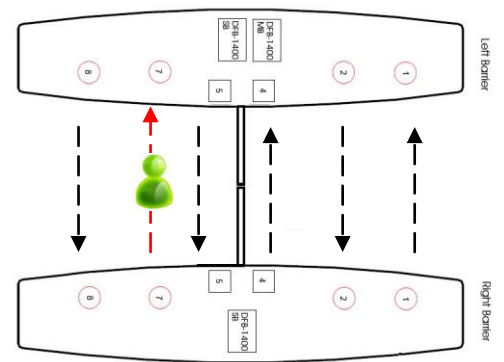

3. INSTALLATION

3.1. Preliminary work on site

Work preliminary to the installation of the equipment will have to be completed in accordance with the implementation plans.

The ground on which the gate will rest must be perfectly flat.

3.2. Storage of the equipment before installation

Avoid any shocks to the equipment and place it in its original packing in a dry place, protected from dust, heat and bad weather.

Storage temperature limits: - 30 °C to +80 °C.

3.3. Opening way for maintenance cover.

Plug in 2 keys, turn toward clockwise direction, the gate can be opened.



3.4 Fixing of the pedestal

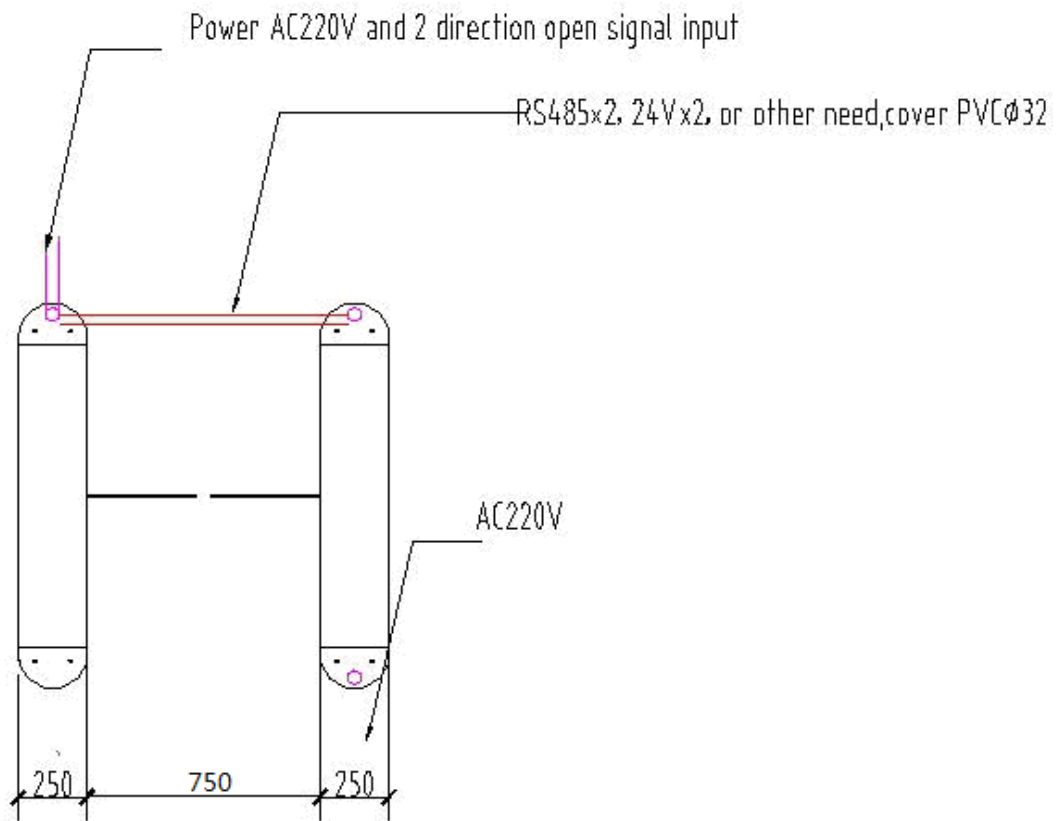

Use 4 M12X100 expansion bolts to fix it, the dimension is as above.

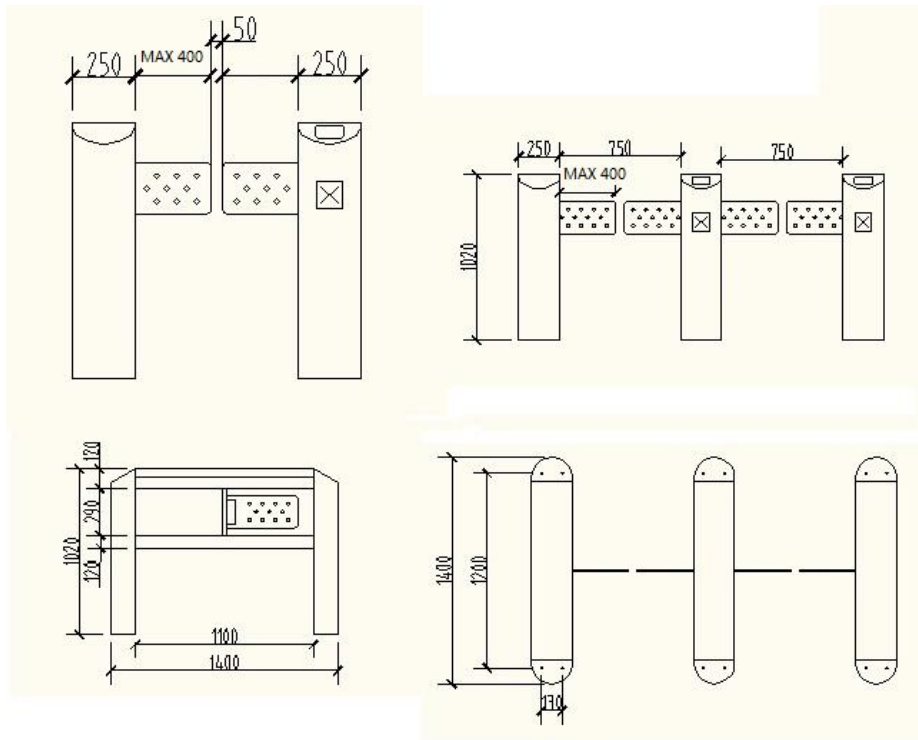

3.5. Electrical connections

The operations must be carried out in accordance with the safety instructions, p3.

1. Get 3 220V single phase power supply inlet wires from the power supply room. Embed them in the middle of barrier. The diameter of wire is 1.5cm² (sleeve required). And connect them to the 220V inlet port of main barrier.
2. Embed several pipelines between lanes to control the communication between two barriers. (see 4th point for details)
3. Embed several controlling circuits in the middle of main barrier for the operations like input open command and other controlling operations. (can see 4.5 inner circuit specification)

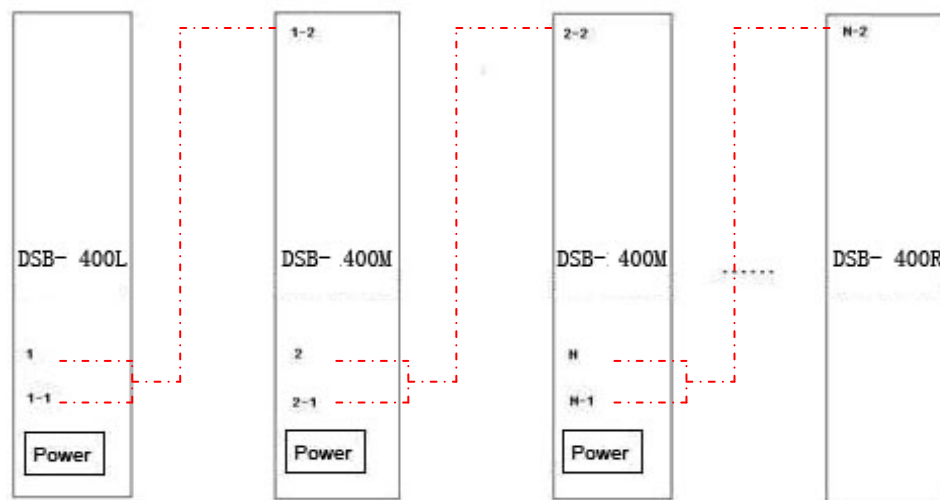

4. Every access is controlled by main board N, slave N-1, slave N-2, please series connect their

power+, power-, RS485+, RS485- and connect IN1, IN2 in main board to the open barrier signal.

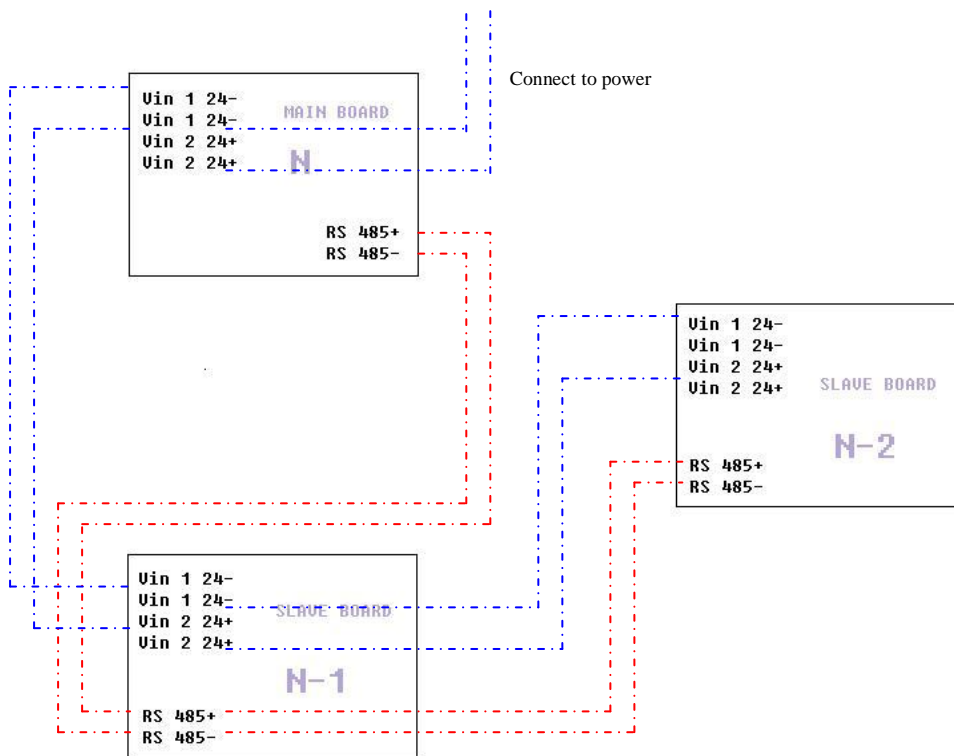

3.6. Install reader

1. Open the lock and put up the top cover
2. Draw the front cover
3. Fixed reader with nuts under the operate symbol
4. Connect the electric connector of reader
5. Turn back the top cover and close maintenance cover.

4. ADJUSTMENTS AND OPERATIONS

4.1. Adjust the limiter

Limit switch is the electrical switching used to limit the running position of mechanical equipment. For this product, limit switch is mainly used to limit the positions of Swing arms. When the Swing barrier runs to the position “open” or “close”, limit switch will be triggered to stop the motor. If the limit switch is invalid, the motor would keep running after running to the limit position with obvious noise, it can cause damage to the equipment.

The limit switch used for this product is Rotary encoder among the several of limit switches. The adjust way include:

1. Software
2. Manual: Keep press the right keypad for 5s and go into the manual adjust mode. Then if keeping the arms in the middle position and choose ‘set slave’ will re- send the middle position of arms default.

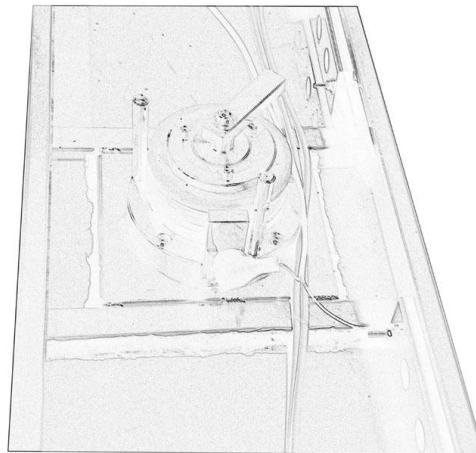

4.2. Adjust the detection cell

Detection cell is made up by detection cell transmitting terminal and detection cell receiving terminal. When the detection cell beam between them is totally covered or covered in a certain percentage, it will have different level signals from the normal occasion. For this product, the display shows: 1—normal, 0—covered.

This product uses 6 pairs of detection cell. They are defined as 1, 2, 3, 4, 5, 7, 8. Among them, 1, 2, 7, 8 are Intrusion detection cell, 4&5 are safety detection cell. (See 2.3 detection cell)

Functions detection: In the default NC mode, cover the receiving terminal of one pair of the detection cell (please do not cover the transmitting terminal to detect), see if the first interface of OLED display shows 0 and if it turns to be 1 after removing the cover (see 4.7 the keyboard

operations of main board). The detection cell are broken if it doesn't change normally.

Detection cell transmitting has 2 wires, brown and blue. The brown one should be connected to power +, blue one should be connected to power -.

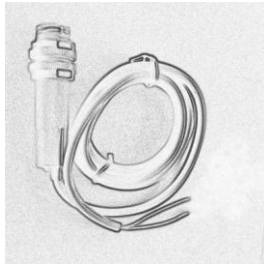

Detection cell receiver has 3 wires, brown, blue and black. The brown one should be connected to power +, blue one should be connected to power -, the black one is data.

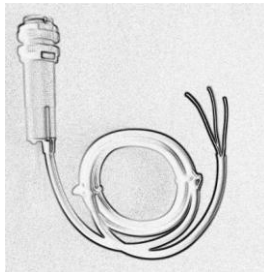

4.3. Replacing the arms

1. Dismount the stainless steel intermediate bar.
2. Dismount the 6 bolts under the Swing arms.
3. Use outside circlip pliers to dismount the clamp ring above the nylon roller.
4. Dismount the Swing arms.
5. Repeat the above steps to install the Swing arms.

4.4. Adjust the clutch

Loose the inner hexangular set screw in the arrowhead position of the following picture

and the 2 inner hexagonal set screw at the bearing in the front. You can move the clutch at horizontal direction. Make the distance between two sub masters as 0.3-0.5mm, and fix the above 3 inner hexagonal set screws.

After debugging, you can connect 24V DC power to the 2 lead wires of clutch to detect it (no +/- difference). Before power on, gear can run freely. After power on, the gear cannot run freely.

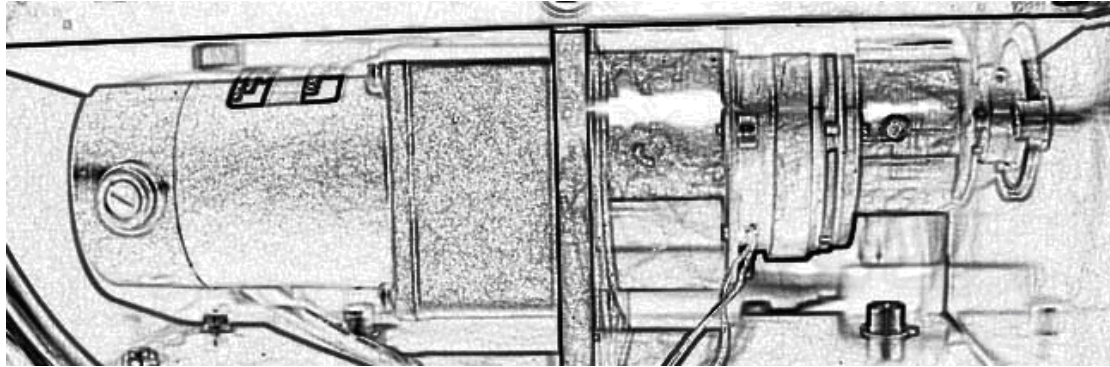

4.5. Detail of inside electronic connection

4.5.1 Main board

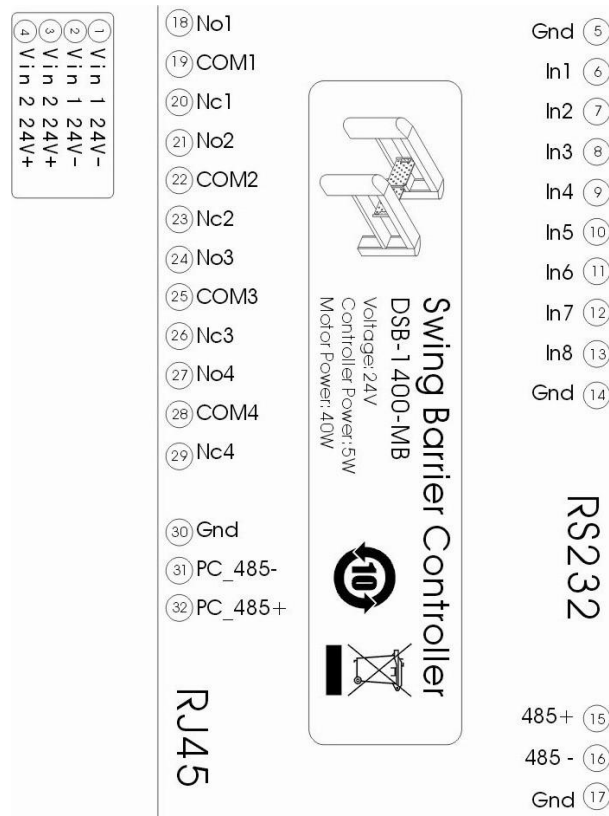

NO1—NC8: Relay output for corresponding event
 NO 1 :Any alarming, relay 1 jumping 0.5s.
 NO 2 :Any passed form direction A, relay 2 jumping 0.5s.
 NO3 : Any passed form direction B, relay 3 jumping 0.5s.

In1: Direction A passage input
 In2: Direction B passage input
 In3: Normal open input (See 5.2.1 normal close mode)
 In4: Normal close input (See 5.2.2 normal open mode)
 In5: Emergency close input(See 5.2.3 emergency close mode)
 In6: Emergency open input(See 5.2.4 emergency open mode)
 In7: Direction A loop input
 In8: Direction B loop input

PC_485+: Connect to PC 485+ for adjusting
 PC_485-: Connect to PC 485- for adjusting

485+: Connect to slave 485+

485+: Connect to PC 485-

4.5.2 Slave board

Slave board includes of left slave board (N-1) which beside the main board and right slave (N-2) which single in side.

Case one: N-1 salve boar

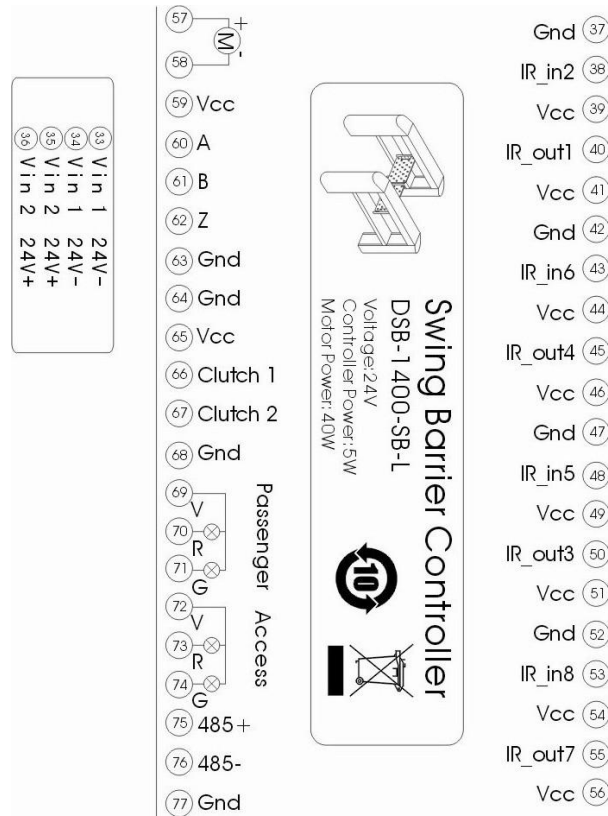

GND: cell 2 receiver blue line

IR_IN2: cell 2 receiver black line

VCC: cell 2 receiver brown line.

IR_OUT1: cell 1 transmitter blue line

VCC: cell 1 transmitter brown line

GND: Null

IR_IN2: Null

VCC: Null

IR_OUT4: cell 4 transmitter blue line

VCC: cell 4 transmitter brown line

GND: cell 5 receiver blue line

IR_IN5: cell 5 receiver black line

VCC: cell 5 receiver brown line.

IR_OUT3: Null

VCC: Null

GND: cell 8 receiver blue line

IR_IN8: cell 8 receiver black line

VCC: cell 8 receiver brown

IR_OUT7: cell 7 transmitter blue line

VCC: cell 1 transmitter brown line

Passenger

V: Connect to Power +

R: Connect to Red Operate symbols

G: Connect to Green Operate symbols

Access

V: Connect to Power +

R: Connect to Red Orientation symbols

G: Connect to Green Orientation symbols

Case two: N-2 salve board

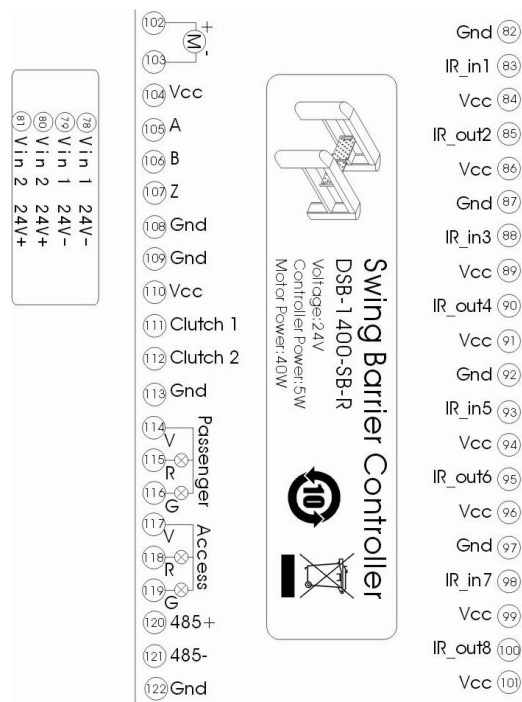

GND: cell 1 receiver blue line

IR_IN1: cell 1 receiver black line

VCC: cell 1 receiver brown line.

IR_OUT2: cell 2 transmitter blue line

VCC: cell 2 transmitter brown line

GND: Null

IR_IN3: Null

VCC: Null

IR_OUT4: cell 4 transmitter blue line

VCC: cell 4 transmitter brown line

GND: cell 5 receiver blue line

IR_IN5: cell 5 receiver black line

VCC: cell 5 receiver brown line.

IR_OUT6: Null

VCC: Null

GND: cell 7 receiver blue line

IR_IN7: cell 7 receiver black line

VCC: cell 7 receiver brown

IR_OUT8: cell 8 transmitter blue line

VCC: cell 8 transmitter brown line

Passenger

V: Connect to Power +

R: Connect to Red Operate symbols

G: Connect to Green Operate symbols

Access

V: Connect to Power +

R: Connect to Red Orientation symbols

G: Connect to Green Orientation symbols

4.6. Software adjust

Delos provide free green software to adjust the arm operation speed by PC, the connection port is RS485 in the main board.

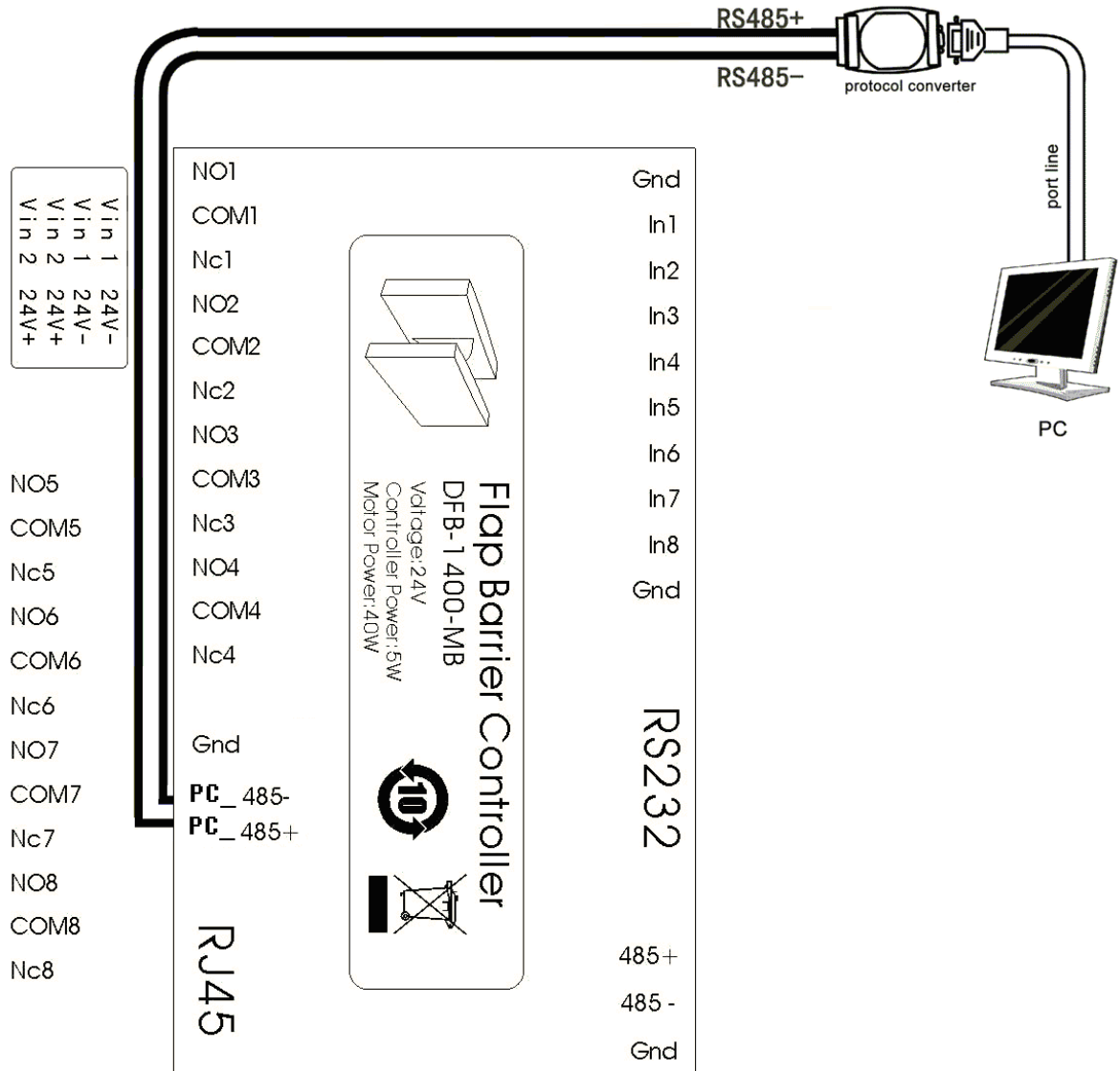

* Be attention of the DATA+ and DATA-, don't be wrong.

4.7 Main board keypad operation

OLED display and keypad

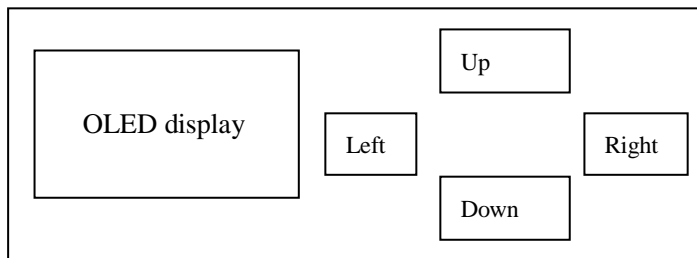

- When the barrier is power on, it will display ‘LOADING’ and system initializing progress bar, that’s mean the barrier is in initializing. Please don’t stand in the passage or shield any detection cell before the initialization finish. Or Swing barrier operate in ‘Reduction Method’ (See 5.2.2 Working Mode). After the default 5s (can be set), the initialization is finished. It will run into the ‘Interface 1’ automatically.
- Input right can change interface 1~7, other keypad has different function in different interface.

Interface 1

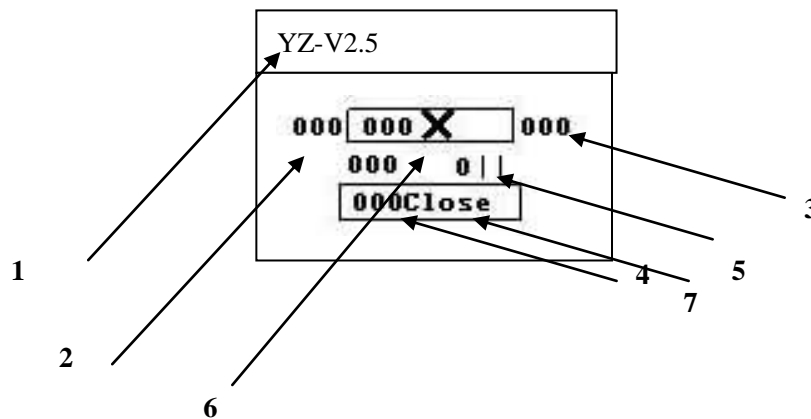

- 1: Firmware version
- 2: Authorized number form left detection
- 3: Authorized number form right detection
- 4: Number of people in access
- 5: Detection cell situation, | means detected block, 0 means no block.
- 6: Swing arm situation, X means open, -- means close
- 7: Operate mode situation, Close means in normal close mode, Open means in normal open mode, Clt-C means in emergent close mode, Clt-O means in emergent open mode.

Interface 2

Control-Mode			
▲	:Left	00	00
◀	:Center	100	
▼	:Right	3C	

This mode is manual control mode, input according button to control the barrier up or down.

Interface 3

Alarm-Code				
--	--	--	--	--
--	--	--	--	--
--	--	--	--	--

This interface display the detection cell and alarming situation in last 21times.

- 1: “Following after authorized passage” intrusion
- 2: “Counter direction” intrusion
- 3: “Standby” intrusion
- 5: Access block
- 7: Detection cell is blocked in NC, NO and Emergent close mode.

Interface 4

Error-Code
Device OK
Device OK
Device OK

Error display interface.

When the device is offline, it shows Device Offline

When detection is error, it shows IrDA Switch Error.

Interface 5

IrDA
IRDA:000**000
Left : 000000000013
Right:000000000003

Detection cell buffer interface.

IrDA: General situation of detection cell

Left: Detection cell situation in left side.

Right: Detection cell situation in right side.

Interface 6

Communication	
ID:1	SN:123456789
Task Waiting:	0
Task Failed:	0

Inner communication, ID No and serial No interface.

ID: Default as 1

SN: Serial No

Task Waiting: Inner communication is running.

Task Failed: The failure times of inner communication.

Interface 7

Online Device			
SL:1	2		
IR 1:	0	IR 2:	0
MT1:	0	MT2:	0

This interface shows the communication between main board and slave board.

SL: Shows if both two boards are successful in communication.

IR1: Shows the infrared communication of No1 control slave board.

IR2: Shows the infrared communication of No2 control slave board.

MT1: Shows the motor communication of No 1 control slave board.

MT2: Shows the motor communication of No 2 control slave board.

5. USE

The operations must be carried out in accordance with the safety instructions, p3.

5.1. Startup

1. Check the installation and connection detailed in ch.3.
2. Check if the maintenance procedures (p) were observed.
3. Switch off the power supply, wait initialization process 5 seconds.
4. Carry out some tests of the electrical opening and closing by means of the controls available (pushbutton, reader, keypad, or other).
5. Check the correct positioning of the barrier in the open and closed position.
6. Check that the barrier opens completely in the event of interruption of the power (correct operation of the "anti-panic" system).
7. Check the correct operation of all the possible options and safety measures.

Working mode

Swing barrier has 5 types of working mode, can be set by the input port of main board (See 4.5.1 Main Board):

- 1) Normal open mode
- 2) Normal close mode
- 3) Emergency open mode
- 4) Emergency close mode
- 5) Degrade mode

5.2.1 Normal close (default mode)

Working process in default mode (Normal close)

1. Don't stand in access or block any detection cell when in first 5s after power on.
2. If the orientation symbol is keep red X means on standby the authorization, if it's flashing red X means this access is not allow to passage now, don't try to authorize till stop flashing.
3. After authorize, the Orientation symbols in authorize direction will be green arrow and orientation symbol in other direction will flashing, means this access is for the authorized people.
4. When the authorized people pass successfully, all the Orientation symbols will resume red X.
5. Swing barrier can record passing right of authorized people for 10s(can be set) before they come in. After 10s(default time) it will be cancel. The max number for authorized record is 255, if more than 255 the oldest will be resumed.

5.2.2 Normal open

1. The function of normal open and normal close mode is almost the same. The difference is in the normal state, the Swing barrier is in normal open mode, that is pass by flashing card and the gate is still open.
2. If detected “Following after authorized passage” intrusion in normal open mode, the barrier will close, authorized again and the gate will open.
3. Through input port 3, you can set the mode to be normal close.

5.2.3 Emergency open mode

This mode is used in applications such as fire alarm, etc.

1. None of the detection cell state can be detected in this mode. The lights on both sides will turn to be green, shows that can pass freely.
2. Through input port 3, can set the mode to be normal close.

5.2.4 Emergency close mode

This mode is used in applications such as fire alarm, etc.

1. Any detection cell state is detected in this mode. Shield all authorization, symbols on both sides are red and flashing.
2. Through input port 3, can set the mode to be normal close.

5.2.5 Degradation mode

This mode appears when the detection cell are broken or blocked during initialization.

1. None of the detection cell state can be detected in this mode. Flashing card is valid. During the passing, detection cell switch would not detect and can not judge, only will close the barrier after the invalid time.
2. By power off, you can recover this mode to be normal close mode. If the same problems come again, there might be some problems with detection cell or circuit.
3. Anti-nip is invalid in this mode. Be careful while using, please find the reason as soon as possible.

Trouble shooting

No.	Problem	Operation
1	Keep alarming after power on	Reset power on Swing barrier and check the detection cell situation whether it's not in the same row or was block (see 4.1. Adjust the limiter)
2	Motor keep working when the arm is in stop position.	Check the limiter (see 4.2. Adjust the detection cell)
3	Initialization fail and OLED display show '?'	Check the inside RS485 transition
4	Input open signal but arms don't open	1. Check the motor 2. If motor is working, check the clutch (see 4.1 adjust clutch)
5	The barrier doesn't reset as soon as passing	1. Check if the barrier is in "Degradation mode" 2. Restart the barrier correctly; If problems are the same, check if the detection cell is OK (see 4.2 Adjust of detection cell for detail)
6	Other malfunctions	Check if the cables are loosen

5.4. Maintenance

The operations must be carried out every 2 months, in accordance with the safety instructions, p3.

1. Clean the bodywork using a product for stainless steel, the frequency of the maintenance must be adjusted according to the conditions of use of the barrier.
2. Clean the barriers using a window cleaning product.
3. Vacuum and clean the masking strip of the cells and their lenses using a soft rag soaked in a non-aggressive cleaning agent. Never use paint thinners or any other organic solvent.
4. Check the state of the electric connections.
5. Add lubricant in the mechanical group.
6. Check the tightening of all the nuts and screws.
7. Carry out the adjustments as chapter 4.